

ASSEMBLY INSTRUCTIONS

B-14

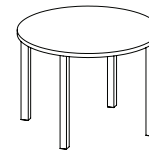

B-14 R

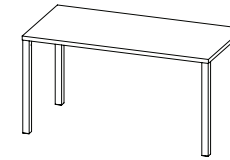

B-14

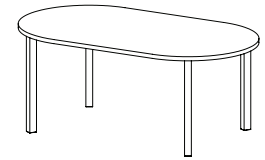

B-14 OV

COMPONENTS

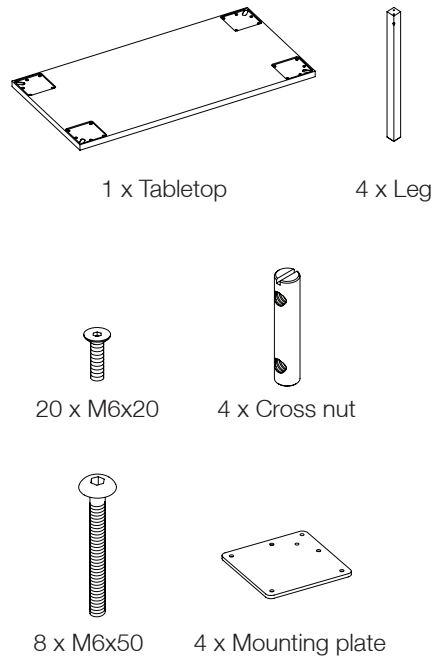

1 Attach the mounting plate to the leg using the cross nut and the M6 bolts. Note that the countersink holes in the mounting plate and the hole for the cross nut in the leg are facing the right way. Use a flathead screwdriver to rotate the cross nut. Use a hex key to screw 2 x M6 bolts, apply **maximum** force. Prepare all legs.

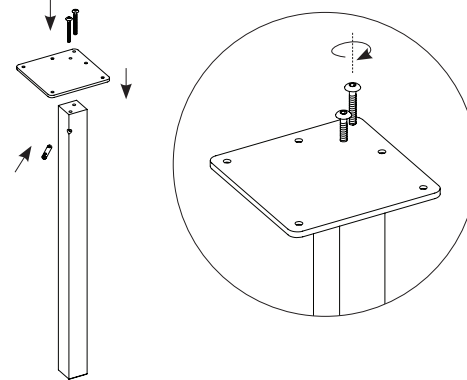

3 Use a hex key to screw 5 x M6 bolts per leg. Apply normal force.

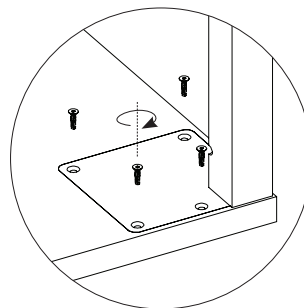

2 Put the tabletop upside down on a protective cover. Now place the assembled leg in the designated cavity. Make sure the leg is facing the corner of the tabletop.

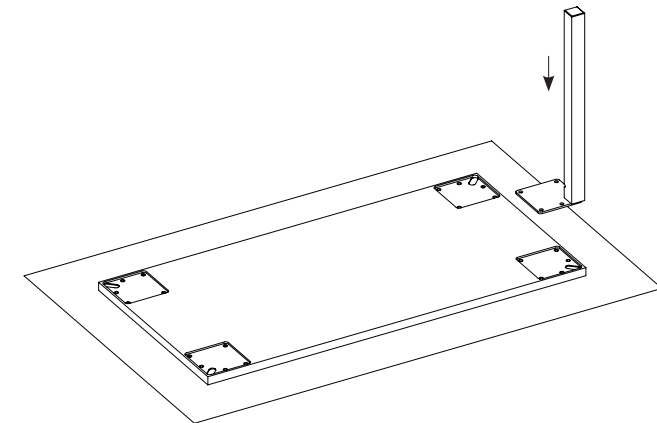

4 Attach all 4 legs and gently turn the table upside down.

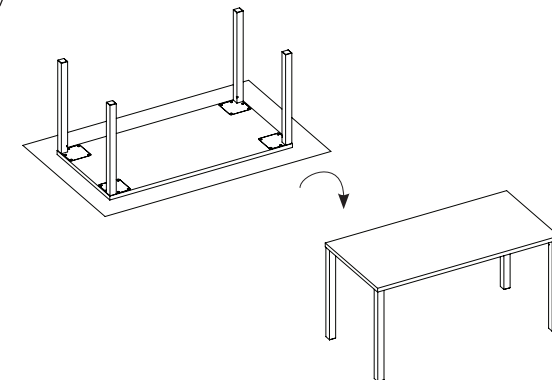

Required tools: hex key,
flat head screwdriver.

MONTERINGSANVISNINGAR

B-14

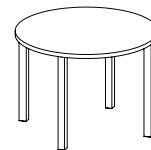

B-14 R

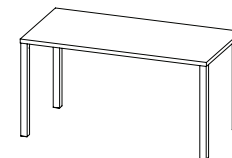

B-14

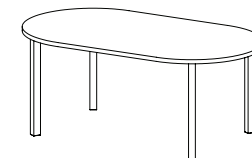

B-14 OV

KOMPONENTER

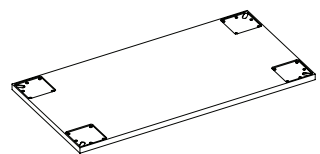

1 x Bordsskiva



4 x Ben



20 x M6x20



4 x Sargsprint

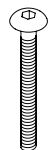

8 x M6x50

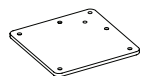

4 x Monteringsplatta

- 1 Fäst monteringsplattan i benet med hjälp av sargsprinten och M6-skruvorna. Notera att försänkning i monteringsplatta samt hålet för sargsprint i ben är åt rätt håll. Använd en spårskruvmejsel för att rotera sargsprinten i rätt läge. Fäst 2 x M6-skrivar med hjälp av en insexnyckel, dra åt **maximalt**. Förbered alla ben.

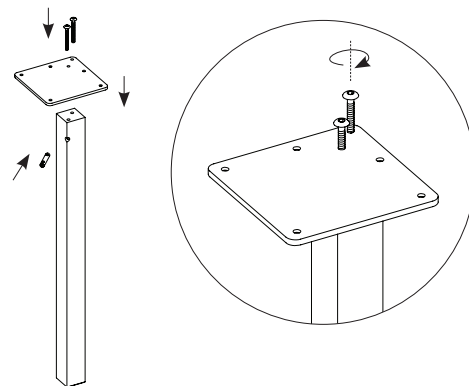

- 3 Fäst 5 x M6-skrivar per ben med en insexnyckel.

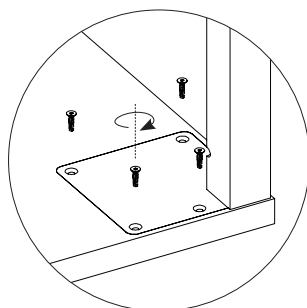

- 2 Läg bordsskivan upp och ner på ett skyddande underlag. Placera det förberedda benet i den hänvisade urtagningen. Var noga med att benet placeras i riktning mot bordsskivans hörn.

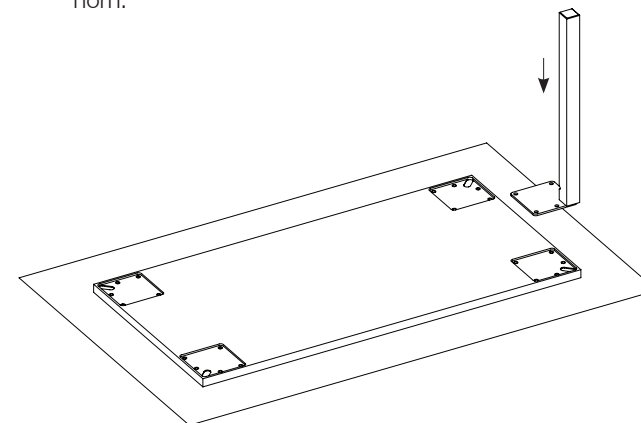

- 4 Fäst alla 4 ben och vänd försiktigt på bordet.

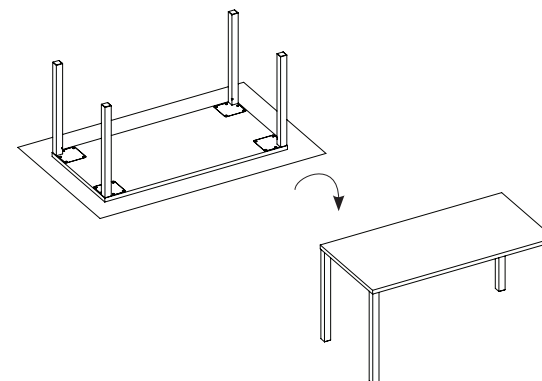

Verktyg för montering: insexnyckel, spårskruvmejsel.